



# Forno Bravo

Authentic Italian Wood-Fired Ovens

## Specification Sheet

### Casa2G Series

#### Modular Refractory Pizza Ovens Kits

#### Professional Wood-Fired Cooking at Home

The Forno Bravo Casa2G Series represents the next generation in residential pizza oven design. Fabricated using the industry's highest quality refractory and insulating materials, the Casa2G ovens offer breakthrough wood-fired cooking performance. These remarkable ovens offer the industry's fastest heat-up times (as fast as 30 minutes) and the longest heat retention times, for perfect pizza making, hearth bread baking, roasting and grilling.

The ovens are available in four sizes, ranging from a 32" to a 44" round. Each Casa2G kit provides everything you need to assemble a world-class pizza oven at your home, including the oven dome, vent and floor, mortar, board and blanket insulation, the oven door, a thermometer, and stainless steel chimney. Building a wood oven has never been so easy.

At the core of the Casa2G ovens are three unique technologies for a residential wood oven:

- The oven dome is produced using a 38% alumina (81% alumina and silica), 135 lb./cu. ft density refractory material cast in a two-sided, vibrated form—a higher quality process than any other residential pizza oven.
- The oven floor is made using large 18"x18"x2" commercial-grade (2,700psi compressed and 2650°F kiln-fired) floor tiles—superior to any other residential oven.
- Each Casa2G kit provides everything you need, including high-tech ceramic oven dome and floor insulation, and a stainless steel chimney—there is nothing else to buy.

Unlike old-fashioned "rustic" or "red" pizza ovens, the Casa2G Series brings the benefits of advanced technology to the homeowner. Each Casa2G oven offers fast heat up times (as little as a remarkable 30 minutes), and maintains its cooking temperature for hours—perfect for pizza parties, bread baking and Thanksgiving roast.

The Casa2G Series features an interlocking dome design with a monoblock vent, making assembly simple. With tighter seams, the Casa2G ovens offer better heat retention and cooking performance, and much better durability than other residential ovens. The Casa2G ovens also provide a fully-sealing door jamb and steel door—essential for baking and roasting.

The Casa2G ovens can be easily installed either on a site-built concrete block stand, or a Forno Bravo metal oven stand. Each Casa2G oven includes everything you need to assemble the oven, including the dome, floor and vent, high temp mortar, steel door, dial thermometer, 24" stainless steel chimney with a rain cap, 3" of dome insulation, and 2" of floor insulation.

A decorative brick arch is available as an option.



Forno Bravo Casa2G110—the perfect wood-fired oven engine.

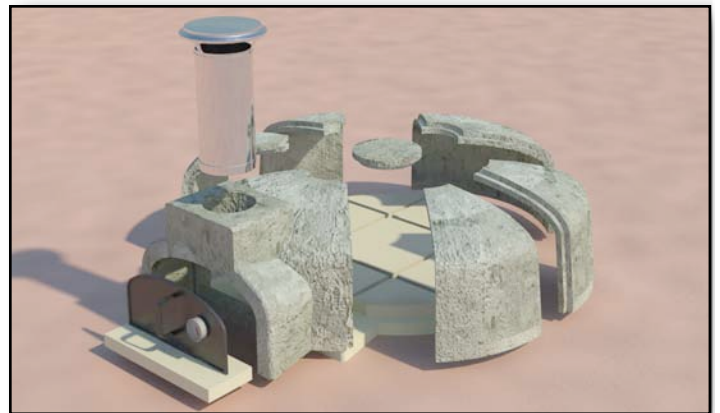

Interlocking dome pieces for better heat retention and durability.

### The Casa2G Family

	Cooking Surface	Area (in <sup>2</sup> )	Heat up	Pizzas (10")	Bread (lb.)
Casa2G80	32"x40"	804	30	1-2	12
Casa2G90	36"x44"	1,017	35	2-3	17
Casa2G100	40"x48"	1,256	40	3-4	22
Casa2G110	44"x52"	1,520	45	4-5	26

744 Neeson Road, Unit A  
Marina, CA 93933  
(800) 407-5119  
info@fornobravo.com  
www.fornobravo.com



### Casa2G Series: Features

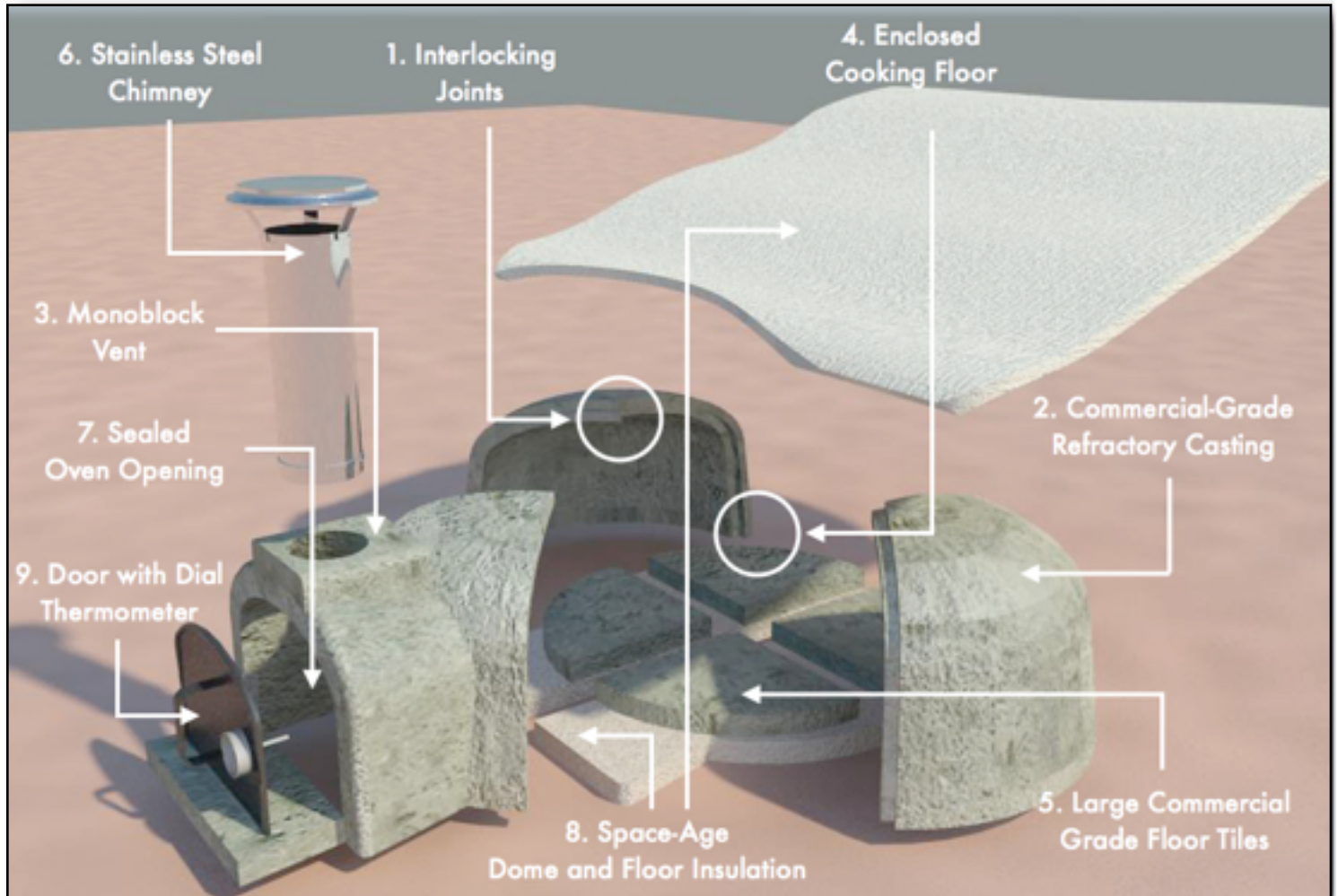

#### 1. Interlocking Dome Design.

Oven pieces seal tightly for easier assembly and better heat retention.

#### 2. Commercial-Grade Refractory Casting.

38% AL2O3 (81% AL2O3/SiO2), 135 lb./cu. ft. vibrated refractory dome for faster heat up and better heat retention.

#### 3. Monoblock Vent.

Solid “true vent” provides excellent draw, less smoke, easy installation and outstanding durability.

#### 4. Enclosed Cooking Floor.

The dome wraps around the floor for better thermal performance.

#### 5. Commercial-Grade Cooking Floor.

Compressed (2,700psi), kiln fired (2650°F) 18”X18”x2” floor tiles have fewer seams, hold heat better and are more durable.

#### 6. Stainless Steel Chimney.

Included 6” or 8” x 24” stainless steel chimney with rain cap snaps directly into the oven for easy assembly.

#### 7. Sealed Oven Opening.

Door jamb enables the oven door to seal the oven chamber from the vent and chimney—controlling the air supply, fire and oven temperature.

#### 8. Complete, Space-Age Oven Insulation

3 x 1” of ceramic dome insulation and 2” floor insulation for easy assembly and excellent heat retention.

#### 9. Metal Door

Steel door closes oven chamber off from vent.

#### 9. Dial Thermometer

Thermometer integrated in steel oven door.

#### Plus. High Temp Mortar

High temp, waterproof mortar for easy oven assembly, and no extra shipping.



# Forno Bravo

Authentic Italian Wood-Fired Ovens

## Specification Sheet

### Casa2G Series: At-a-Glance

	Casa2G80	Casa2G90	Casa2G100	Casa2G110
Cooking Floor	32"W x 40"D	36"W x 44"D	40"W x 48"D	44"W x 52"D
External Dimensions	36"W x 42"D x 19"H	40"W x 46"D x 19"H	44"W x 50"D x 20"H	48"W x 54"D x 20"H
Oven Opening	17"W x 10"H	17"W x 10"H	20"W x 10.5"H	20"W x 10.5"H
Vent Landing	20.5"W x 8"D	20.5"W x 8"D	23.5"W x 8"D	23.5"W x 8"D
Dome Height	15"	15"	16"	16"
Monoblock Oven Opening and Vent	✓	✓	✓	✓
Sealing Door Jamb	✓	✓	✓	✓
Vent Opening Diameter	6"	6"	8"	8"
Chimney Type	Single wall steel, UL103, or clay	Single wall steel, UL103, or clay	Single wall steel, UL103, or clay	Single wall steel, UL103, or clay
Commercial Grade, Kiln-Fired Cooking Floor	✓	✓	✓	✓
3" Ceramic Blanket Insulation	75 sq. ft.	100 sq. ft.	125 sq. ft.	150 sq. ft.
2" Floor Ceramic Board Insulation	6 sq. ft.	7 sq. ft.	8 sq. ft.	9 sq. ft.
High Temp, Waterproof Mortar	25 lbs.	25 lbs	50 lbs.	50 lbs.
Pizza Peel	✓	✓	✓	✓
24" Stainless Steel Chimney with Cap	✓	✓	✓	✓
Steel Door with Thermometer	✓	✓	✓	✓
Dome Pieces	3	3	5	7
Pizzas at a Time	2	3	5	7
Heat Up Time	40 minutes	45 minutes	45 minutes	50 minutes
Weight (dome, vent and floor)	590 lbs.	670 lbs.	830 lbs.	940 lbs.



# Forno Bravo

Authentic Italian Wood-Fired Ovens

## Specification Sheet

# Casa2G: Assembly

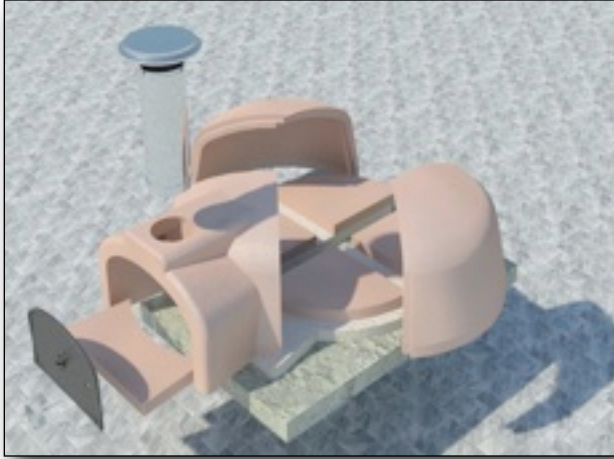



# Forno Bravo

Authentic Italian Wood-Fired Ovens

## Specification Sheet

# Casa2G: The Competition

	Casa2G	Typical Italian "Rustic" or "Red" Oven
Commercial-Grade, Vibrated High-Density Dome	✓	Definitely not.
Interlocking Dome Assembly	✓	No. That's too difficult.
Monoblock Refractory Oven Opening and Vent	✓	No way.
Commercial-Grade, Kiln-Fired Cooking Floor	✓	No. That's too expensive.
Complete 3" Dome Ceramic Blanket Insulation	✓	Not even close.
Complete 2" Floor Ceramic Board Insulation	✓	No. That's not available.
High Temp, Waterproof Mortar	✓	No. That costs extra.
Stainless Steel Chimney with Cap	✓	No. That costs a lot extra.
Lots of Additional Shopping, Shipping and Expense	No.	✓
Pricing	A lot less than you would expect.	\$\$\$\$



# Forno Bravo

Authentic Italian Wood-Fired Ovens

## Specification Sheet

# Casa2G: Which Size is Right?

### **Casa2G80**

Our smallest Casa2G oven, the Casa2G80 delivers fast heats up times, and can cook two small, or one medium pizza a time. It is the right oven for tight spaces.

- 32" round cooking surface
- 8" deep oven landing for staging and warming food
- 2 10" pizzas
- 12 1 lb. loaves of bread
- One large chicken
- 2 roasting pans

### **Casa2G90**

The Casa2G90 is our most popular oven size, cooking three personal pizzas at a time, as well as roasts and vegetables.

- 36" round cooking surface
- 8" deep oven landing for staging and warming food
- 3 10" pizzas
- 17 1 lb. loaves of bread
- One small turkey (or large chicken)
- 2 roasting pans

### **Casa2G100**

Popular with the cooking enthusiast, the Casa2G100 provides more space for multiple roasting pans, along with room for more pizza and bread.

- 40" round cooking surface
- 8" deep oven landing for staging and warming food
- 5 10" pizzas
- 22 1 lb. loaves of bread
- One large turkey
- 3 roasting pans

### **Casa2G110**

Perfect for the serious chef, or neighborhood host, the Casa2G110 can be the center of attention for larger parties and family events.

- 44" round cooking surface
- 8" deep oven landing for staging and warming food
- 7 10" pizzas
- 26 1 lb. loaves of bread
- One large turkey
- 4 roasting pans



# Forno Bravo

Authentic Italian Wood-Fired Ovens

# Specification Sheet

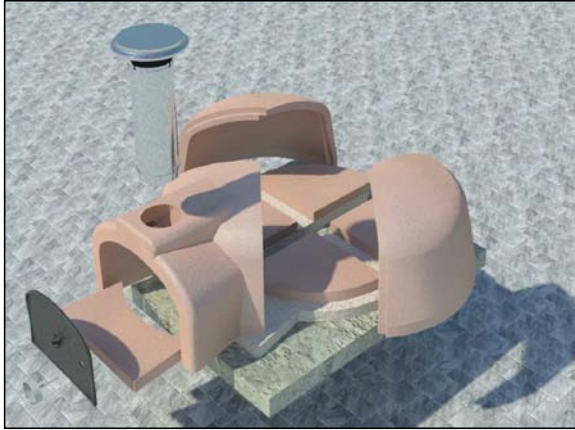

3D VIEW

NOT TO SCALE

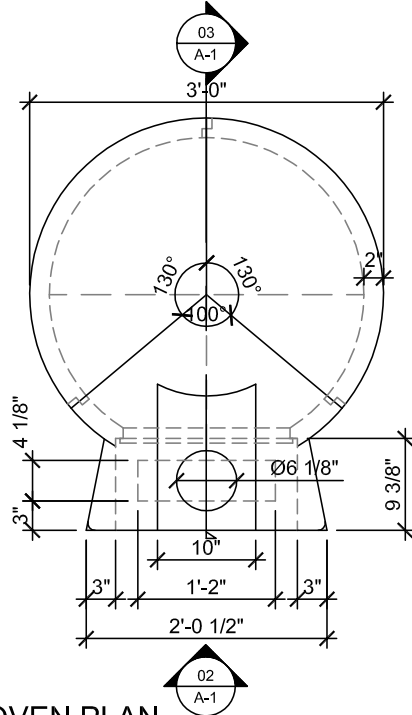

01 OVEN PLAN

SCALE: 3/4"=1'-0"

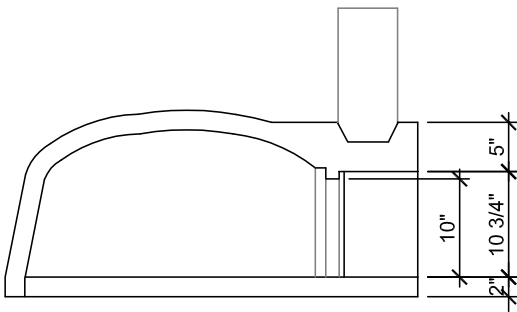

03 SIDE ELEVATION

SCALE: 3/4"=1'-0"

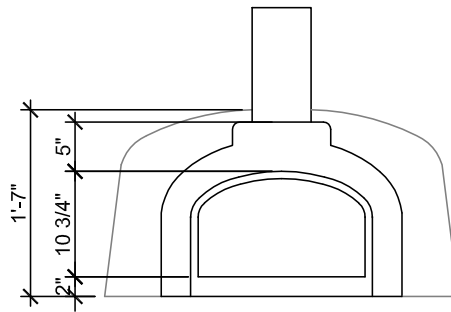

02 FRONT ELEVATION

SCALE: 3/4"=1'-0"

A-1

FORNO BRAVO, LLC  
CASA2G80

Project number 0913

Date 9.9.09

Drawn by MC





# Forno Bravo

Authentic Italian Wood-Fired Ovens

## Specification Sheet

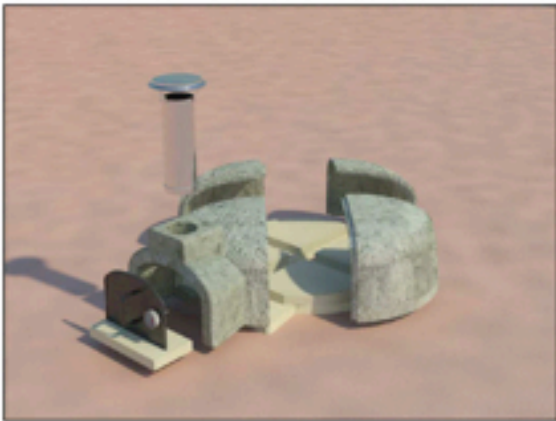

**3D VIEW**

NOT TO SCALE

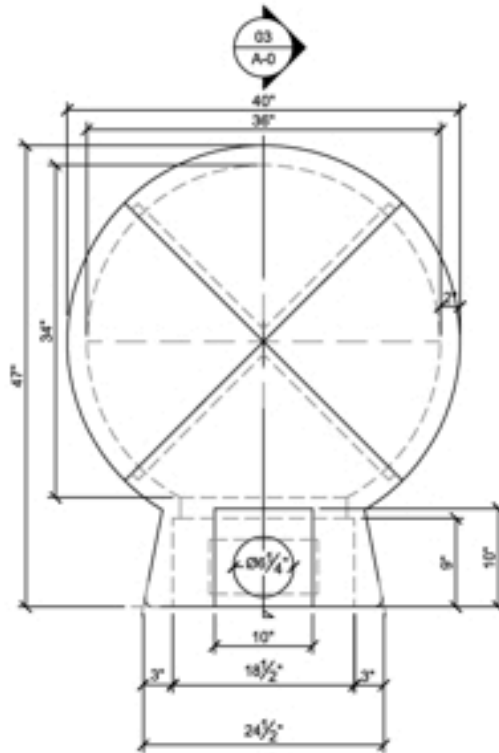

**01 OVEN PLAN**  
A-0 SCALE: 3/4"=1'-0"

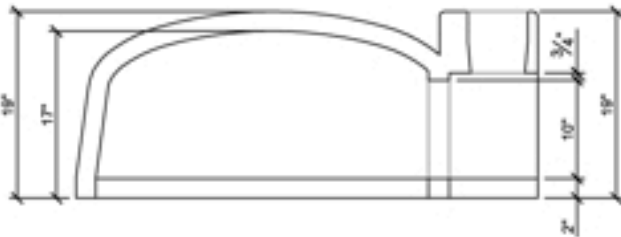

**03 SIDE ELEVATION**  
A-0 SCALE: 3/4"=1'-0"

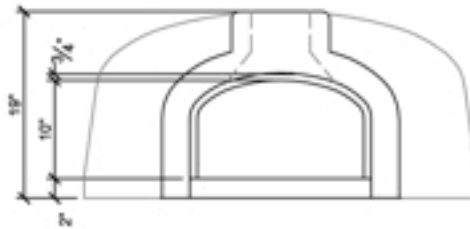

**02 FRONT ELEVATION**  
A-0 SCALE: 3/4"=1'-0"

A-0

**FORNO BRAVO, LLC**  
**CASA2G90**

Project number 0918  
Date 11.1.09  
Drawn by MC







# Forno Bravo

Authentic Italian Wood-Fired Ovens

## Specification Sheet



3D VIEW

NOT TO SCALE

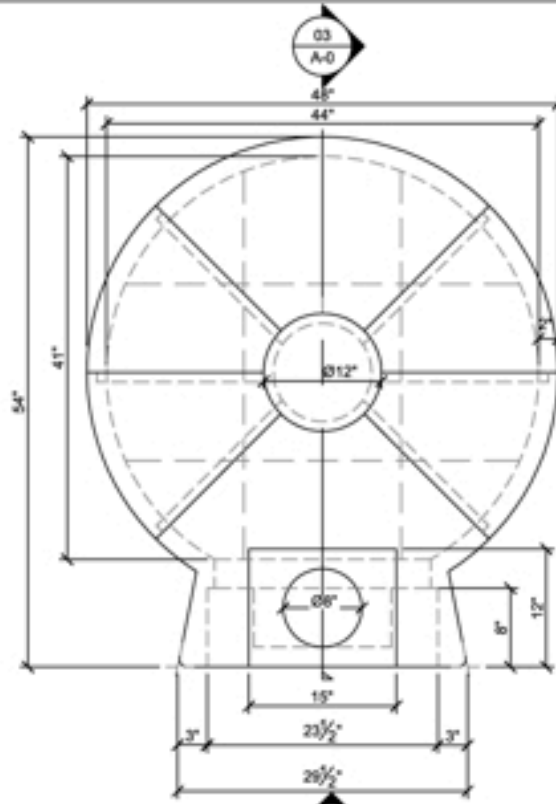

01 OVEN PLAN  
A-0 SCALE: 3/4"=1'-0"

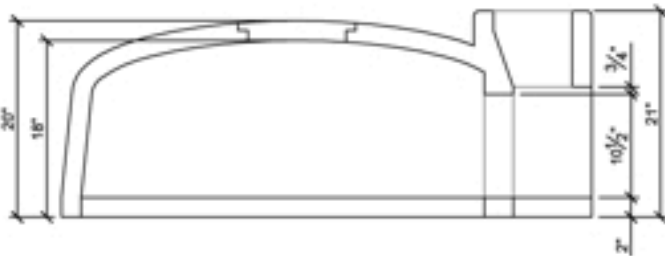

03 SIDE ELEVATION  
A-0 SCALE: 3/4"=1'-0"

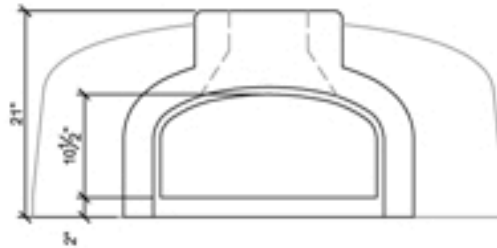

02 FRONT ELEVATION  
A-0 SCALE: 3/4"=1'-0"

A-0

FORNO BRAVO, LLC  
CASA2G110

Project number 0918  
Date 11.1.09  
Drawn by MC

