



## Primavera Series Wood Pizza Ovens

### Real Wood-Fired Cooking; Real Easy

The Primavera Series is a family of fully-assembled pizza ovens. These innovative ovens delivers a true Italian wood-fired cooking experience in a package designed to fit in almost any backyard or patio—and most budgets. Using high-tech refractories and space-age insulators, the Primavera ovens strike the perfect balance between capability and performance, and size and weight. Both ovens require virtually zero assembly, and they can be set up without specialized tools or equipment.

The Primavera60 offers a 24” cooking floor, and comes with a decorative metal stand, while the Primavera70 delivers more cooking space with a 28” cooking floor—though it must be placed on an owner-provided stand or cooking island.

These fully assembled ovens are the right choice for homeowners who do not have the space, time or budget for a larger Italian wood-fired oven, but still want to enjoy authentic wood-fired cooking, Vera Pizza Napoletana and hearth bread. The Primavera60’s 24” internal round cooking floor is large enough for true “fire-in-the-oven” pizza baking and roasting, where the 28” Primavera70 oven is capable of baking multiple pizzas at a time, and handling a larger number of roasting pans or loaves of bread. Both ovens offer a larger usable cooking surface than other small wood-fired ovens.

Both Primavera ovens features a 6” oven landing, which is perfect for keeping food warm, and for holding pots and roasting pans as they go in and out of the oven.

The ovens also include a traditional Italian-style vent and chimney. The chimney is essential to proper oven operation, allowing efficient heat movement for authentic high-heat cooking. On a practical note, it keeps hot air and smoke away from the chef, and keeps the front of the oven less sooty.

The Primavera60 oven’s attractive black powder-coated metal stand can be set up using a standard wrench.

Using state-of-the-art refractory materials, including aluminate castables and mortars, woven ceramic insulation and a sophisticated custom, multi-layer insulating hearth, the Primavera oven combines fast heat-up time (as quick as 20 minutes) and excellent heat-holding capabilities. The outer shell of the oven stays cool, while the oven chamber easily maintains 750°F plus, to bake authentic Italian pizza in 2-3 minutes. The oven dome and floor are rated for operation at temperatures up to 2300°F—far greater than the oven would ever reach.

The oven includes a steel door. Optional accessories include a pizza placing peel, a round turning peel, an oven brush, oven rake, oven shovel and infrared thermometer.



Fully finished and ready to cook; Just set it down and go.

### The Primavera Oven

	Cooking Surface (in)	Area (in <sup>2</sup> )	Heat up (min)	Pizzas (10")	Bread (lbs)
<b>Primavera60</b>	24”	452	20	1	10
<b>Primavera70</b>	28”	615	20	2	14

### Each Primavera Oven includes

Complete oven with metal door

### Oven Specifications

#### Primavera60

Internal cooking floor: 24” round  
Oven landing: 6” deep  
Oven opening: 16” wide x 9.5” high  
Oven width: 37”  
Enclosure height: 64” (from the ground)  
Cooking floor height: 38” (from the ground)  
Weight: about 450 pounds (not including the stand)

#### Primavera70

Internal cooking floor: 28” round  
Oven landing: 6” deep  
Oven opening: 16” wide x 9.5” high  
Oven width: 41”  
Enclosure height: 26” (from the base to the enclosure top)  
Weight: about 600 pounds

744 Neeson Road, Unit A  
Marina, CA 93933  
(800) 407-5119  
info@fornobravo.com  
www.fornobravo.com



# Forno Bravo

Authentic Italian Wood-Fired Ovens

# Specification Sheet

## Primavera60 Dimensions

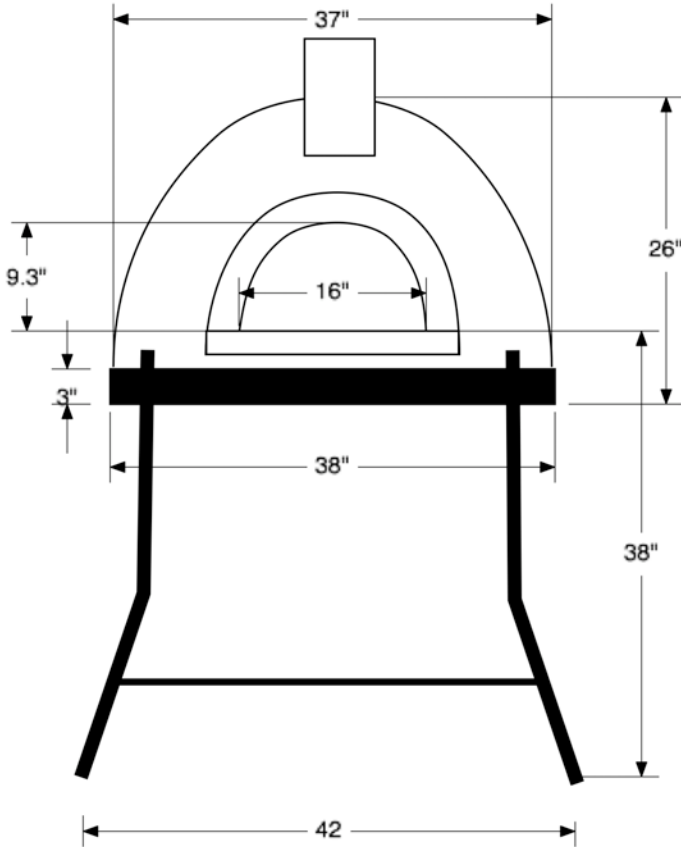

## Primavera70 Dimensions

